

E. G. THOMAS.

SELF PLAYING MUSICAL INSTRUMENT.

APPLICATION FILED MAR. 15, 1912. RENEWED MAR. 9, 1916.

1,186,050.

Patented June 6, 1916.

Fig. 1.

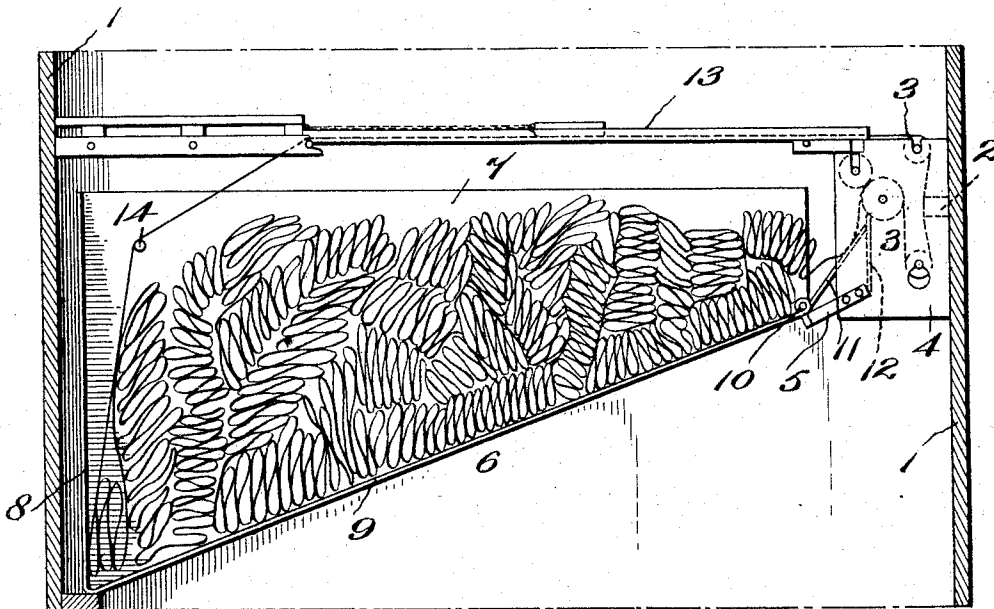
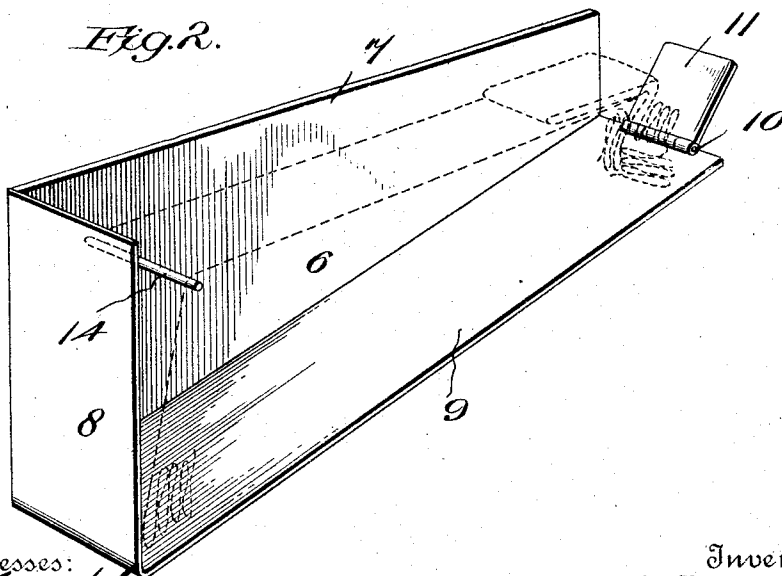

Fig. 2.



Witnesses:
J. A. Mumby
R. James Cronin

Inventor
Elisha G. Thomas
By *Geo. A. Squire*
Attorney

UNITED STATES PATENT OFFICE.

ELISHA GOODELL THOMAS, OF WASHINGTON, DISTRICT OF COLUMBIA, ASSIGNOR, BY DIRECT AND MESNE ASSIGNMENTS, TO EDWIN A. LINK, OF BINGHAMTON, NEW YORK.

SELF-PLAYING MUSICAL INSTRUMENT.

1,186,050.

Specification of Letters Patent.

Patented June 6, 1916.

Application filed March 15, 1912, Serial No. 684,068. Renewed March 9, 1916. Serial No. 83,168.

To all whom it may concern:

Be it known that I, ELISHA GOODELL THOMAS, a citizen of the United States of America, residing at 201 East Capitol street, Washington, District of Columbia, have invented a certain new and useful Improvement in Self-Playing Musical Instruments, of which the following is a specification.

This invention relates to new and useful improvements in self-playing musical instruments and more particularly to a receptacle for holding the perforated note sheet. Heretofore in receptacles of this character it has been necessary on account of the long length of the endless band to employ a sheet conveying mechanism for feeding the band and it has been found that the conveying mechanism not only causes confusion of the folds, but wears and tears the sheet and that in case of repair to the instrument, the mechanism has to be detached and the entire sheet has to be rewound.

The primary object of the invention is to provide a novel form of receptacle for receiving the sheet, which is in the form of an endless band, and convey it from the receiving or tracker end to the discharge end without the usual conveying or controlling mechanism. Heretofore removable receptacles have on account of their location often presented an unsightly appearance and have not only contained the endless tune sheet but the tune sheet rollers as well.

A further object of this invention is to provide a receptacle of the character set forth that may be conveniently located within the instrument casing and one which can be easily removed with only the endless sheet therein.

A still further object is to provide a receptacle of the character described that will be cheap to manufacture; one that will be capable of holding a sheet containing a large number of musical pieces and one that will be easy on the paper, thereby preventing the paper from becoming confused and torn.

To these ends the invention consists in the novel details of construction and combination of parts more fully hereinafter described and particularly pointed out in the claims.

Referring to the accompanying drawings forming a part of this specification in which like numerals designate like parts in all the views: Figure 1 is a sectional view of a por-

tion of a self-playing instrument showing my improved receptacle attached thereto and Fig. 2 is a perspective view of my improved receptacle shown detached from the instrument.

1 indicates the casing of a self-playing piano at one end of which is located the tracker feed mechanism, comprising the tracker board 2 and series of feed rolls 3. Connected to the frame 4, which supports the tracker feed mechanism, is a downward extending bracket 5 which supports one end of the receptacle 6, the other end of which is supported by a portion of the casing 1.

The receptacle preferably of the shape shown is adapted to receive the endless sheet and comprises a back wall 7, end wall 8 and sloping bottom 9, to the upper end of which is pivotally connected as at 10 a guide plate 11 which guide plate is adapted to rest against the shield or guard 12, of the tracker mechanism, for guiding the endless sheet into the receptacle after it leaves the tracker feed mechanism. A flat table 13, over which the sheet is adapted to be drawn, is connected to the instrument casing above the receptacle 6 and is adapted to properly guide the sheet to the tracker board.

During the operation of the instrument and after the sheet passes the tracker feed mechanism it is guided by the plate 11 into the receptacle where it is doubled up into a series of folds, which folds are constantly increasing and partly on account of their weight and partly on account of their pressure gradually slide down the inclined bottom to the delivering end. The bottom is preferably formed of a material having very smooth surface which greatly aids the travel of the sheet down its inclined plane. After the sheet has reached the delivery end of the receptacle it is then carried over the guide rod 14 mounted therein to the table 13 and back over the same to the tracker board.

When the receptacle is desired to be removed to obtain free access to the working parts of the instrument during repairs it is only necessary to remove the sheet from the table and feed rolls in the usual manner place the removed portion on top of the folds and swing the guide plate free of the edge of the frame which supports the tracker feed mechanism.

From the foregoing it may be seen that with a self-playing musical instrument

60

85

70

75

80

85

90

95

100

105

110

equipped with my invention a great saving will be effected both in the cost of production and repair of the instrument, and numerous other defects may be remedied and overcome.

It is obvious that those skilled in the art may vary the details of construction and arrangement of parts without departing from the spirit and scope of my invention and therefore I do not wish to be limited to such features except as may be required by the claims.

What I claim is:—

1. A holder for endless music sheets for self playing instruments, comprising, in combination with a sheet delivery table, a tracker bar, and guiding rolls adjacent to said tracker bar, a receptacle adapted to be withdrawn from the back of the instrument and to be supported within the instrument at a point below the plane of the sheet delivery table thereof, said receptacle having a bottom inclined downwardly from the point of the tracker mechanism of the instrument to the opposite end of said instrument whereby to permit the sheet folds to gravitationally accumulate immediately at the point of discharge of the receptacle, the receptacle having an open end adapted to be disposed in line with the sheet guiding rolls of the instrument, and means forming a part of the receptacle and adapted to be disposed beneath said sheet guiding rolls whereby to deflect the sheet onto the inclined bottom of the receptacle as the sheet leaves said rolls.

2. A holder for endless tune sheets for self playing instruments, comprising, in combination with a sheet delivery table, a tracker bar, and guiding rolls adjacent to said tracker bar, a receptacle embodying three walls, one of said walls being inclined downwardly from the point of the tracker bar of the instrument to another wall of the receptacle, the other wall of the receptacle being disposed immediately at the lower end of the inclined wall and forming a stop to limit the fall of the tune sheet thereon as the sheet is discharged from the guiding rolls of the instrument, and means within the receptacle for guiding the sheet onto the delivery table of the instrument.

3. A holder for tune sheets for self playing instruments, comprising, in combination with a sheet delivery table, a tracker bar, and guiding rolls adjacent to said tracker bar, a wall inclined downwardly toward one end of the instrument and from the tracker bar, a second wall disposed at the extreme lower end of the first wall, a third wall rising from the first wall at one side thereof, the third wall having a length equal to the length of said inclined wall, sheet guiding

means extending from one of the walls, and a pivoted plate located at the upper end of the inclined wall and adapted to extend in the direction of the sheet guiding rolls of the tracker mechanism of the instrument.

4. A holder for tune sheets for self playing instruments, comprising sheet guiding table, sheet guiding rolls and tracker mechanism, a receptacle adapted to be adjusted horizontally through the back of the casing of the instrument and to contain an endless tune sheet whereby one leaf of the sheet may be placed over the sheet guiding table of the instrument on adjustment of the receptacle to an operative sheet feeding position, the receptacle having an open end adapted to be disposed in line with the sheet guiding rolls of the tracker mechanism of the instrument.

5. A holder for endless music sheets for auto-pneumatic instruments comprising in combination with the tracker feed mechanism, a receptacle adapted to be secured to the instrument and having a wall downwardly inclined toward one end of the receptacle whereby to permit the sheet folds to gravitationally accumulate immediately at the point of discharge of the receptacle and means within the receptacle for guiding the sheet to the tracker feed mechanism.

6. A holder for endless music sheets for auto-pneumatic instruments comprising in combination with the tracker feed mechanism, a receptacle adapted to be detachably secured to the instrument and having a wall downwardly inclined toward one end of the receptacle whereby to permit the sheet folds to gravitationally accumulate immediately at the point of discharge of the receptacle and means within and located at both ends of the receptacle for guiding the sheet to the tracker feed mechanism.

7. A holder for endless music sheets for auto-pneumatic instruments comprising in combination with the tracker feed mechanism, a receptacle adapted to be detachably secured to the instrument, and having a wall downwardly inclined toward one end of the receptacle whereby to permit the sheet folds to gravitationally accumulate immediately at the point of discharge of the receptacle, and means located at the discharge end of the receptacle for guiding the sheet to the tracker feed mechanism.

In testimony whereof, I ELISHA GOODELL THOMAS have signed my name to this specification in the presence of two subscribing witnesses, this thirteenth day of March, 1912.

ELISHA GOODELL THOMAS.

Witnesses:

I. J. MACFARREN,
A. D. PHILLIPS.